



ICEIS 2005

***SEVENTH INTERNATIONAL CONFERENCE ON
ENTERPRISE INFORMATION SYSTEMS***

Proceedings

Volume 1

MIAMI, U.S.A. · May 25-28, 2005

ORGANIZED BY

INSTICC

**Institute for Systems and Technologies
of Information, Control and
Communication**

CO-ORGANIZED BY



IN COOPERATION WITH



VOL. I - DATABASES AND INFORMATION SYSTEMS INTEGRATION

FULL PAPERS

A PROTOTYPE FOR INTEGRATION OF WEB SERVICES INTO THE IRULES APPROACH TO COMPONENT INTEGRATION <i>Susan D. Urban, Vikram V. Kumar and Suzanne W. Dietrich</i>	3
WRAPPING AND INTEGRATING HETEROGENEOUS RELATIONAL DATA WITH OWL <i>Seksun Suwanmanee, Djamel Benslimane, Pierre-Antoine Champin and Philippe Thiran</i>	11
DWG2XML: GENERATING XML NESTED TREE STRUCTURE FROM DIRECTED WEIGHTED GRAPH <i>Kate Y. Yang, Anthony Lo, Tansel Özyer and Reda Albaji</i>	19
THE INDEX UPDATE PROBLEM FOR XML DATA IN XDBMS <i>Beda Christoph Hammerschmidt, Martin Kempa and Volker Linnemann</i>	27
CWM-BASED INTEGRATION OF XML DOCUMENTS AND OBJECT-RELATIONAL DATA <i>Iryna Kozlova, Martin Husemann, Norbert Ritter, Stefan Witt and Natalia Haenikel</i>	35
ARCO: A LONG-TERM DIGITAL LIBRARY STORAGE SYSTEM BASED ON GRID COMPUTATIONAL INFRASTRUCTURE <i>Han Fei, Paulo Trezentos, Nuno Almeida, Miguel Lourenço, José Borbinha and João Neves</i>	44
CHANGE DETECTION AND MAINTENANCE OF AN XML WEB WAREHOUSE <i>Ching-Ming Chao</i>	52
DYNAMIC PRE-FETCHING OF VIEWS BASED ON USER-ACCESS PATTERNS IN AN OLAP SYSTEM <i>Karthik Ramachandran, Biren Shah and Vijay Raghavan</i>	60
CHOOSING GROUPWARE TOOLS AND ELICITATION TECHNIQUES ACCORDING TO STAKEHOLDERS' FEATURES <i>Gabriela N. Aranda, Aurora Vizcaino, Alejandra Cebich and Mario Piattini</i>	68
SECURING THE ENTERPRISE DATABASE <i>V. Radha, Ved P. Gulati and N. Hemant Kumar</i>	76
CRITICAL SUCCESS FACTORS IN ERP PROJECTS: CASE STUDIES IN TWO INDUSTRIAL ORGANIZATIONS IN THE NETHERLANDS <i>Jos J.M. Trienekens, Wouter Knijpers and Ruud Hendriks</i>	84
CONDITIONS FOR INTEROPERABILITY <i>Nick Rossiter and Michael Heather</i>	92
MUSICAL RETRIEVAL IN P2P NETWORKS UNDER THE WARPING DISTANCE <i>Ioannis Karydis, Alexandros Nanopoulos, Apostolos N. Papadopoulos and Yannis Manolopoulos</i>	100
AN EFFICIENT APPROACH FOR WEB-SITE ADAPTATION <i>Seema Jani, Sam Makki and Xiaobua Jia</i>	108
THE HYBRID DIGITAL TREE: A NEW INDEXING TECHNIQUE FOR LARGE STRING DATABASES <i>Qiang Xue, Sakti Pramanik, Gang Qian and Qiang Zhu</i>	115
REAL-TIME SALES & OPERATIONS PLANNING WITH CORBA: LINKING DEMAND MANAGEMENT WITH PRODUCTION PLANNING <i>Elias Kirche, Janusz Zalewski and Teresa Tharp</i>	122

CHOOSING GROUPWARE TOOLS AND ELICITATION TECHNIQUES ACCORDING TO STAKEHOLDERS' FEATURES

Gabriela N. Aranda

*Departamento de Ciencias de la Computación, Universidad Nacional del Comahue
Buenos Aires 1400, Neuquén, Argentina
Email: garanda@uncoma.edu.ar*

Aurora Vizcaíno

*Departamento de Informática – Universidad de Castilla-La Mancha
Paseo de la Universidad 4, Ciudad Real, España
Email: Aurora.Vizcaino@uclm.es*

Alejandra Cechich

*Departamento de Ciencias de la Computación, Universidad Nacional del Comahue
Buenos Aires 1400, Neuquén, Argentina
Email: acechich@uncoma.edu.ar*

Mario Piattini

*Departamento de Informática – Universidad de Castilla-La Mancha
Paseo de la Universidad 4, Ciudad Real, España
Email: Mario.Piattini@uclm.es*

Keywords: Groupware, Distributed Cooperative Work, Distributed Requirements Elicitation, Cognitive Informatics.

Abstract: The set of groupware tools used during a distributed development process is usually chosen by taking into account predetermined business politics, managers' personal preferences, or people in charge of the project. However, perhaps the chosen groupware tools are not the most appropriate for all the group members and it is possible that some of them would not be completely comfortable with them. To avoid this situation we have built a model and its supporting prototype tool which, based on techniques from psychology, suggests an appropriate set of groupware tools and elicitation techniques according to stakeholders' preferences.

1 INTRODUCTION

Software development in scenarios where stakeholders are in many geographically distributed sites, seems to be more common every day. The multi-site development is a current matter of study and discussion, especially about people who are involved in those virtual teams. It is a fact that during a traditional requirement elicitation process, stakeholders must face many problems that have been detected and analysed for decades (Brooks, 1987; Davis, 1993; Loucopoulos, 1995). When participants are distributed distance affects processes

of communication, coordination and control and has consequences along all the software development process (Damian, 2004), specially during the requirement elicitation process which is critically based on communication between stakeholders (SWEBOK, 2004). In addition to barriers in communication, other obstacles appear, like problems in knowledge management, stakeholders' cultural diversity and time differences between different sites (Damian, 2002).

There are some areas of research that try to minimize the impact of these problems. One of them is the CSCW (Computer-Supported Cooperative Work), which takes into account both human

behaviour and the technical support people need to work as a group in a more productive way. This technical support is called groupware and is one of the main subjects of our study. On the other hand, as another approach to solve same problems of distributed requirements elicitation, the use of Cognitive Informatics is increasing day by day.

Cognitive Informatics (Chiew, 2003; Wang, 2002) is a profound interdisciplinary research area that tackles the common root problems of modern informatics, computation, software engineering, artificial intelligence (AI), neural psychology, and cognitive science. One of the most interesting things found in cognitive informatics is that it embodies many science and engineering disciplines, such as informatics, computing, software engineering, and cognitive sciences, which share a common root problem: *how natural intelligence processes information*.

Considering that the quality of the requirements is influenced by the techniques employed during requirement elicitation (Hickey, 2003) and the role that groupware tools play when communicating in virtual teams (Damian, 2002), we aim at improving virtual teams performance by applying concepts from cognitive informatics. We are particularly interested in some techniques from the field of psychology, which are called Learning Style Models (LSM). LSM classify people according to the way in which they perceive and process information, and analyse relationships between students and instructors. Considering that during requirement elicitation a person acts like student and instructor alternatively; we propose using LSM as a base for improving the requirements elicitation process. In doing so, we propose choosing a set of groupware tools and elicitation techniques that support not only the communication itself but also the stakeholders' preferences.

With this in mind, in the following sections we present some basic concepts about groupware tools, and learning style models. In section four, we describe a model that supports stakeholders' personal preferences in geographically distributed processes, and an automatic tool that uses the previous model. In section five we present some related works. Conclusions are addressed in the final section of the paper.

2 CSCW AND GROUPWARE

CSCW is an acronym that refers to research into experimental systems and the nature of organizations, while groupware focuses on technologies (Grudin, 1994).

Generally speaking, groupware is software to enable communication between cooperating people who work on a common task. It may include different communication technologies, from simple plain-text chat to advanced videoconferencing (Gralla, 1996). To avoid ambiguities we will refer to every simple piece of communication technology as a groupware tool, and to the systems that combine them as groupware packages.

The most common groupware tools used during multi-site developments are e-mails, newsgroups and mailing lists, electronic discussion or forums, electronic notice or bulletin boards, asynchronous and synchronous shared whiteboards, document sharing, chat, instant messaging, and videoconferencing (Damian, 2002; Gralla, 1996; Herlea, 1998).

At first glance, groupware tools can be divided into *synchronous* and *asynchronous*; whether the users have to work at the same time or not (Ellis, 1991). Synchronous tools are, for instance, chat and videoconferencing, while e-mails, forums, and document sharing are asynchronous.

Some authors note the importance of using both types of tools in group work. Asynchronous collaboration is important because it allows team members to construct requirements individually and contribute to the collective activity of the group for a later discussion. This is significant when groups are distributed across time zones because of the difficulty in scheduling real time meetings. Also, real time collaboration and discussions seem to be necessary components of group requirements elicitation sessions, in such a way that, by means of synchronous tools, stakeholders have the chance of getting instant feedback (Herlea, 1998).

A second classification of groupware tools can be made according to the way in which they show the information. Some of them are based primarily on images, figures, diagrams, etc., like shared whiteboards, videoconferencing; while others do it by predominantly using words, for instance, chat, e-mails, newsgroups, mailing lists, forums, etc.

3 LEARNING STYLE MODELS

A learning process involves two steps: *reception* and *processing* of information.

During the first step, people receive external information –which is observable through senses– and internal information –which emerges from introspection–, then they select a part to process and ignore the rest. Processing involves memorization or reasoning (inductive or deductive), reflection or action, and introspection or interaction with others

(Felder, 1996; Felder, 1988).

Learning Style Models (LMS) classify people according to a set of behavioural characteristics pertaining to the ways they receive and process information and this classification is used to improve the way people learn a given task.

These models have been discussed in the context of analysing relationships between instructors and students. We have tried to take advantage of this model and discussions by adapting their application to a virtual team that deals with a distributed elicitation process. To do so, we consider an analogy between stakeholders and roles in LSM since during the elicitation process everybody “learns” from others. In this way stakeholders play the role of student or instructor alternatively, depending on the moment or the task they are carrying out (Martin, 2003).

After analysing five LSM in (Martin, 2003) we found out that every item in the other models was included in the model proposed by Felder-Silverman (Felder, 1988), so that we may build a complete reference framework choosing this as a foundation.

The Felder-Silverman (F-S) Model classifies people into four categories, each of them further decomposed into two subcategories as follows: *Sensing/Intuitive*; *Visual/Verbal*; *Active/Reflective*; *Sequential/Global*. Each subcategory has the following significant characteristics:

Sensing people prefer learning facts. They like solving problems by well-established methods and dislike complications and surprises. Sensors tend to be patient with details and good at memorising facts and doing hands-on (laboratory) work. On the contrary, *intuitive people* often prefer discovering possibilities and relationships. They like innovation and dislike repetition. They tend to work faster and to be more innovative than sensors. Intuitors do not like work that involves a lot of memorisation and routine calculations.

Visual people remember best what they see (such as pictures, diagrams, flow charts, time lines, films, and demonstrations). They prefer visually presented information. On the other hand, *verbal people* get more out of words, and written and spoken explanations. They prefer verbally presented information.

Active people tend to retain and understand information by doing something active with it (discussing or applying it or explaining it to others). “Let’s try it out and see how it works” is an Active’s phrase. In contrast, *reflective people* prefer to think about information quietly first. “Let’s think it through first” is the Reflective’s response.

Sequential people tend to gain understanding in linear steps, with each step following logically from

the previous one. They tend to follow logical stepwise paths in finding solutions. They may not fully understand the material but they can nevertheless do something with it (like solve homework problems or pass a test) since the pieces are logically connected. Contrarily, *global people* tend to work in large jumps, absorbing material almost randomly without seeing connections, and then suddenly “getting it”. They may be able to solve complex problems quickly or put things together in novel ways once they have grasped the big picture, but they may have difficulty explaining how they did it.

Classification into the different categories is made by a multiple-choice test proposed by Solomon-Felder. As a result, each person gets a rank for each category that suggests his or her preference.

People may fit into one category or the other depending on the circumstances: people may be “sometimes” active and “sometimes” reflective. The preference for one category may be *strong*, *moderate*, or *mild*. Only when there is a strong preference, can people be catalogued as a member of a certain group.

4 OUR PROPOSAL

4.1 The Model

Before proposing a methodology for supporting distributed elicitation we think it is necessary to determine the aspects that have to be considered and the way in which they relate to each other.

With the aim of recommending a set of suitable groupware tools and elicitation techniques during a particular elicitation process, we have defined a model, which is depicted in Figure 1, and whose primary concepts and relationships are now described:

- **Virtual Team**

Virtual team (Peters, 2003) virtual community (Geib, 2004), distributed group (Lloyd, 2002) are terms used to refer to a group of people who work together on a project. Their main characteristic is their distribution over many sites, and the use of information technology to communicate and coordinate efforts.

In our model the common project or task which they carry out is the elicitation process, which is the process of “extract and inventory the requirements from a combination of human stakeholders” (SWEBOK, 2004).

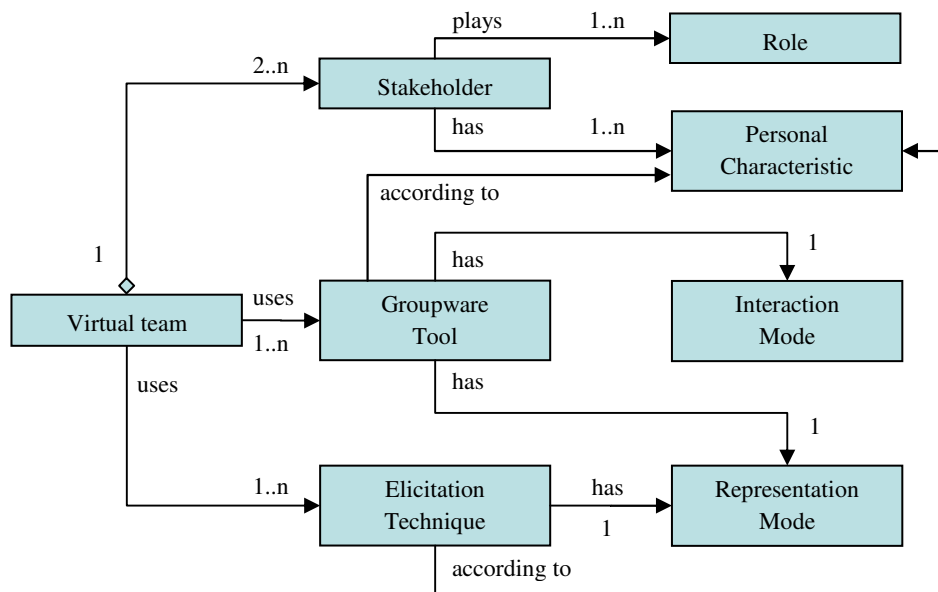

Figure 1: A model to support personal preferences in a virtual community

- **Stakeholder**

A stakeholder is defined as “a person, such as an employee, [...], who is involved with an organization, [...] and therefore has responsibilities towards it and an interest in its success” (Cambridge Dictionary, 2004).

Typical stakeholders are users (those who will operate the system), customers (those who have commissioned the system), system developers, etc. (SWEBOK, 2004).

Each person in a virtual team is supposed to play (at least) one **Role** during the elicitation process, and, as it is a person, he or she has some **Personal Characteristics** that tell us about his or her preferences when he/she perceives and process information.

- **Groupware Tools**

As we have mentioned before, groupware is software to enable communication. According to the way in which they show the information, groupware tools have different **Representation Modes** (based on figures or diagrams, or based on spoken or written words) and different **Interaction Modes** (for instance, synchronous or asynchronous).

- **Elicitation Techniques**

Elicitation is fundamentally a human activity where communication plays a transcendental role (SWEBOK, 2004).

Requirement engineers may face some difficulties, usually because users cannot clearly

describe their tasks, or because they are not completely disposed to cooperate.

The election of elicitation techniques plays a very important role in distributed teams. Since face-to-face interaction is not possible, techniques have to be adapted to be used in combination with groupware. Some techniques that seem to be adaptable to the distributed elicitation process are question and answer methods, customer interviews, brainstorming, idea reduction, storyboards, prototyping, questionnaires, and use cases (Lloyd, 2002).

Like groupware tools, elicitation techniques have different **Representation Modes** (based on images or based on words).

Relationships between these concepts can be expressed generally as:

- A **Virtual Team** represents a group of **Stakeholders** that work cooperatively on a common task (which in our case is the Elicitation Process).
- **Stakeholders** play **Roles** that imply rights and responsibilities that have to do with their job. In our case the roles involved in the elicitation process are: users, clients, managers, analysts, project managers, etc.
- **Stakeholders** communicate with each other using some **Groupware Tools** and build different models of a problem using a set of **Elicitation Techniques**.

- **Groupware Tools**, as well as **Elicitation Techniques**, are supposed to be chosen according to the stakeholders' **Personal Characteristics**, in order to make them feel comfortable and improve their performance.
- Each **Groupware Tool** has a **Representation Mode** (verbal or visual) and an **Interaction Mode** (synchronous or asynchronous), which are important in deciding the suitability for a stakeholder's personal preferences.
- In a similar way, each **Elicitation Technique** has a predominant **Representation Mode** (verbal, visual, or a possible good combination of both) that we will take into account to suggest their use or non-use.

4.2 Applying LSM to choose Groupware Tools

In order to support personal preferences, in (Martin, 2003) we have proposed a classification of groupware tools focusing on Visual/Verbal and Active/Reflective categories of the F-S model. The classification is based on the description and the strategies suggested by Felder and Silverman for each subcategory. The results of such classifications are shown in Figure 2. The sign “++” is used to indicate those groupware tools which are more suitable for people with a strong preference for a given subcategory. The sign “+” indicates that a groupware tool would be mildly preferred by a stakeholder with those characteristics. Finally, the sign “-” suggests that a particular groupware tool would be “not suitable” for that particular subcategory.

Also, we have proposed a way of choosing a set of groupware tools for a given group of stakeholders. To do so we suggest representing the

information we know about each participant in a two-way matrix that collects their preferences for categories Visual/Verbal and Active/Reflective. By doing so, we can have a view of stakeholders' preferences in general and, according to the quadrant that contains more instances, choose those groupware tools that adapt to most people in the group. Figure 3 shows an example of such a matrix.

In (Aranda, 2004), we have presented a model based on fuzzy logic and fuzzy sets, which aims to obtain rules, given a set of representative examples, that tell us about the stakeholders' preferences in their daily use of groupware tools.

The model takes four inputs (X_1, X_2, X_3, X_4), which are the preferences for each category of the F-S Model, and an output variable (Y) that is the preference for one of a given set of groupware tools.

For each input variable we have defined a domain using the adverbs (and their correspondent abbreviations): Very (V), Moderate (M) and Slight (S). These adverbs correspond to *strong*, *moderate* and *mild*, respectively, in the F-S model, but we have changed their names to avoid confusion with respect to the use of the first letter.

For instance, the definition domain for the category Reflective-Active would be: Very reflective (VRe), Moderately reflective (MRe), Slightly reflective (SRe), Slightly active (SAc), Moderately active (MAc), Very active (VAc).

Using a machine learning algorithm it is possible to obtain rules such as “ R_0 : if X_1 is VAc and X_3 is VVi then y is IM”, which is interpreted as: “If a user has a strong preference for the Active subcategory and a strong preference for the Visual subcategory, the tool that this person would prefer is Instant Messaging”

In a similar way it is possible to find a suitable set of elicitation techniques according to the preferences for each category of the F-S model.

		Visual	Verbal	Active	Reflective
Asynchronous Tools	E-mails	+	++	-	++
	Mailing lists, Newsgroups	-	++	-	++
	Asynch. shared whiteboards	++	-	-	++
	Forums	-	++	-	++
Synchronous Tools	Instant messaging	+	++	++	-
	Synch. shared whiteboards	++	-	++	-
	Chat	-	++	++	-
	Videoconferencing	++	++	++	-

Figure 2: Classification of groupware tools according to category' descriptions of the F-S model

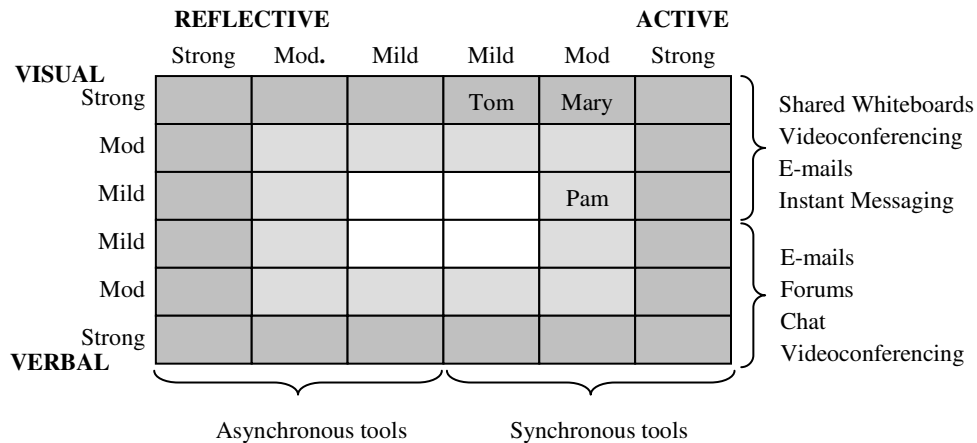

Figure 3: Choosing a set of groupware tools according to F-S Model categories

4.3 A tool to automate the selection process

As we have previously explained we aim to find a set of groupware tools and elicitation techniques that are suitable for a given group of stakeholders. By trying to do this in an automatic way we have designed a prototype tool.

By means of our tool, stakeholders are asked to fill in a multiple-choice test so as to know their preferences. This information is maintained throughout the cooperative process.

Once a group of stakeholders is defined and their preferences detected, our tool analyses them, using the sets of rules previously generated. As a result it returns the most suitable groupware tools and elicitation techniques for that group of people.

The tool's architecture has been designed basically on three layers:

- **Lower Layer – Persistent Data**
It keeps the information concerning personal preferences of stakeholders, rules of suitability preferences-groupware tools and rules of suitability preferences-elicitation techniques.
- **Middle Layer – Application logic**
It contains those components that interact with the database and interface layers in order to find information and, by applying the appropriate algorithms, analyses it and produces a suitable answer.

- **Upper Layer – User Interface**

It is the layer that contains all those components with which users of the tool interact.

Figure 4 shows a screen of our prototype tool where three stakeholders (Mary, Tom and Pam) are interacting.

Information about their predominant personal characteristics is shown on the upper right hand side of the screen. On the bottom there are two lists of suggested groupware tools and elicitation techniques that would be most suitable for them.

5 RELATED WORK

Some related work concerning analysis of groupware tools and elicitation techniques in distributed teams is found in literature:

In (Damian, 2002) a case study is described of a real multi-site organization that uses a mix of synchronous and asynchronous tools, like teleconferencing, a common repository of documents, email, and other Internet technologies. The authors collected data from inspecting documents, observed requirements meetings, and performed semi-structured interviews with stakeholders. As a conclusion, some of the points that stakeholders note as problems –which are especially interesting for us– are the lack of informal or face-to-face communication and the difficulty in sharing drawings on a whiteboard during spontaneous discussions.

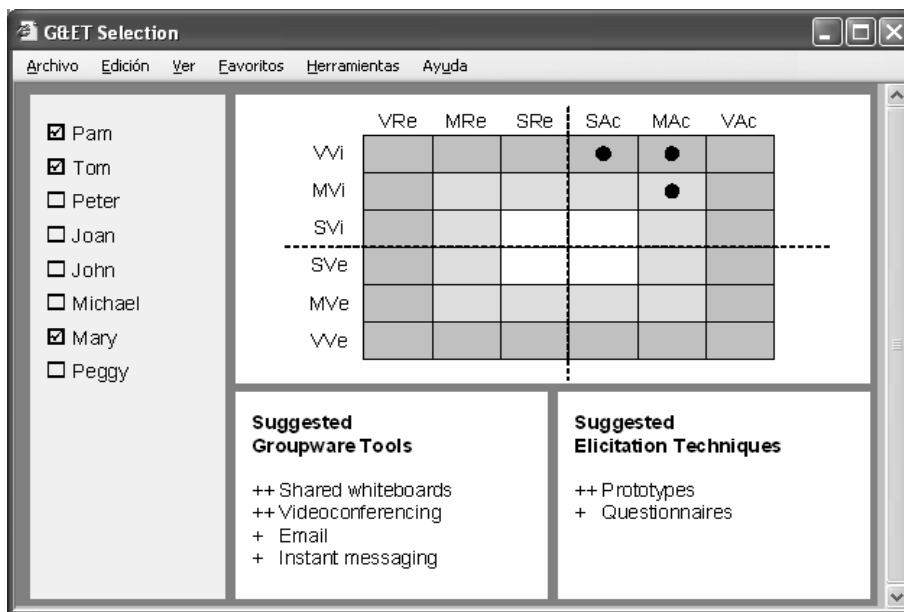

Figure 4: An interface that shows the suggestions for a particular group of stakeholders

Another example is reported in (Lloyd, 2002) and shows the results of an exploratory empirical study about effectiveness of requirement engineering in a distributed setting. Students from different graduate Software Engineering courses played the role of customers or engineers in separate groups. They used a previously selected set of groupware tools: audio-conferencing and chat for synchronous communication, and email for file sharing and asynchronous discussions. They could do just four planned audio-conferencing meetings, (no more than 19 minutes each), while the use of other technologies was not restricted. They were able to use a wide set of requirement elicitation techniques. Participants playing the role of software engineers wrote a Software Requirements Specification (SRS) document using only the knowledge gained from remote collaboration with customers. After SRS documents were produced, a set of metrics was applied to assess document quality. They concluded that students who played the role of software engineers chose the techniques according to previous experience and instruction in the course. Data collected suggested that groups producing high quality SRS were those that had only used the synchronous tools and did not need to use email and asynchronous elicitation methods.

Both case studies have interesting points for us. However, we think that different conclusions could be reached if aspects relative to personal characteristics had been applied. Why did students who wrote the highest quality SRS documents not need to use email to communicate with their

customers?: It may be because their personal characteristics were suitable for synchronous tools, while those who needed email interaction needed more time to think and prepare questions or answers so that synchronous communication was not the best form for them; or it may be that they needed “to see” the words written, and audio-conferencing was not appropriate. With reference to the results obtained in (Damian, 2002), the need to use a whiteboard to draw during discussions indicates people with a strong preference for visual tools.

In (Carrizo Moreno, 2004), a survey of works where theories, empirical analysis and comparisons between different elicitation techniques is presented. It focuses on the fact that elicitation techniques are chosen without having a valid guide to select the best one.

6 CONCLUSIONS

Today, many organisations have adopted a decentralised, team-based, distributed structure where members communicate through groupware tools. The selection of appropriate technology and elicitation techniques in such environments is a subject of study in current literature.

By means of improving communication during the elicitation process, we think it is possible to improve the elicitation process itself. When stakeholders feel comfortable with the technology and methodologies they use, information gathered during elicitation is expected to be more accurate.

Stakeholders might feel more comfortable expressing their ideas and describing facts by using a tool closer to the way they perceive and reason about the world.

In this paper, we have proposed a model and its supporting tool to relate stakeholders' learning preferences to communication tools and elicitation techniques – more suitable according to those preferences. However, an aspect that needs further discussion is the possibility of solving conflicts when stakeholders' preferences seem to be opposite. We are working on that restriction.

Additionally, as a future work we are using this tool in academic and industrial environments, in order to evaluate how it behaves in real situations and analyse its effectiveness in virtual teams.

REFERENCES

- Aranda, G., Cechich, A., Vizcaíno, A. and Castro-Schez, J. J. (2004). Using fuzzy sets to analyse personal preferences on groupware tools. *X Congreso Argentino de Ciencias de la Computación, CACIC 2004*, San Justo, Argentina, pp. 549-560.
- Brooks, F. P. (1987). No Silver Bullet: Essence and accidents of Software Engineering. *IEEE Computer* 4(20), pp. 10-19.
- Cambridge Dictionary (2004). Cambridge Advanced Learner's Dictionary. Cambridge Dictionaries Online, <<http://dictionary.cambridge.org/>>. Cambridge University Press 2004.
- Carrizo Moreno, D. (2004). Selección de Técnicas de Educación de Requisitos: Una Revisión Conjunta de la Ingeniería de Software y la Ingeniería del Conocimiento. *IV Jornadas Iberoamericanas de Ingeniería del Software e Ingeniería del Conocimiento, IIISIC 2004*, Madrid, Spain, pp. 159-174.
- Chiew, V. and Wang, Y. (2003). From Cognitive Psychology to Cognitive Informatics. *Second IEEE International Conference on Cognitive Informatics, ICCI'03*, London, UK, pp. 114-120.
- Damian, D., Lanubile, F., Hargreaves, E. and Chisan, J. (2004). Workshop Introduction. *3rd International Workshop on Global Software Development. Co-located with ICSE 2004*, Edinburgh, Scotland.
- Damian, D. and Zowghi, D. (2002). The impact of stakeholders geographical distribution on managing requirements in a multi-site organization. *IEEE Joint International Conference on Requirements Engineering, RE'02*, Essen, Germany, pp. 319-328.
- Davis, A. (1993). *Software Requirements: Objects, Functions and States*. New Jersey, Prentice Hall. Upper Saddle River.
- Felder, R. (1996). Matters of Styles. *ASEE Prism* 6(4), pp. 18-23.
- Felder, R. and Silverman, L. (1988). Learning and Teaching Styles in Engineering Education. *Engineering Education* 78(7), pp. 674-681.
- Geib, M., Braun, C., Kolbe, L. and Brenner, W. (2004). Measuring the Utilization of Collaboration Technology for Knowledge Development and Exchange in Virtual Communities. *37th Hawaii International Conference on System Sciences, HICSS-38*, Big Island, Hawaii, pp. 1-10.
- Gralla, P. (1996). *How Intranets Work*. Emeryville, California, Ziff-Davis Press.
- Grudin, J. (1994). Computer-Supported Cooperative Work: History and Focus. *IEEE Computer* 27(5), pp. 19-26.
- Herlea, D. and Greenberg, S. (1998). Using a Groupware Space for Distributed Requirements Engineering. *7th IEEE Int'l Workshop on Coordinating Distributed Software Development Projects*, Stanford, California, USA, pp. 57-62.
- Hickey, A. M. and Davis, A. M. (2003). Elicitation Technique Selection: How do experts do it? *International Joint Conference on Requirements Engineering (RE03)*, Los Alamitos, California, IEEE Computer Society Press, pp. 169-178.
- Ellis, C.A.; Gibbs, S.J. and Rein, G.L. (1991). Groupware: Some Issues and Experiences. *Comm. of ACM* 34 (1), pp. 38-58.
- Lloyd, W., Rosson, M. B. and Arthur, J. (2002). Effectiveness of Elicitation Techniques in Distributed Requirements Engineering. *10th Anniversary IEEE Joint International Conference on Requirements Engineering, RE'02*, Essen, Germany, pp. 311-318.
- Loucopoulos, P. and Karakostas, V. (1995). *System Requirements Engineering*. New York, NY, USA. Mc Graw-Hill. International series in Software Engineering.
- Martin, A., Martinez, C., Martinez, N., Aranda, G. and Cechich, A. (2003). Classifying Groupware Tools to Improve Communication in Geographically Distributed Elicitation. *IX Congreso Argentino de Ciencias de la Computación, CACIC 2003*, La Plata, Argentina, pp. 942-953.
- Peters, L. (2003). The Virtual Environment: The "How-to" of Studying Collaboration and Performance of Geographically Dispersed Teams. *Twelfth IEEE International Workshops on Enabling Technologies: Infrastructure for Collaborative Enterprises, WETICE'03*, Linz, Austria, pp. 137-141.
- SWEBOK (2004). *Guide to the Software Engineering Body of Knowledge*. Software Engineering Coordinating Committee (IEEE-CS y ACM).
- Wang, Y. (2002). On Cognitive Informatics. *First IEEE International Conference on Cognitive Informatics, ICCI'02*, Calgary, Alberta, Canada, pp. 34-42.